

ENGLISH

**L-1D
INSTRUCTION MANUAL
(Mechanical)**

CONTENTS

IMPORTANT SAFETY INSTRUCTIONS	i
FOR SAFE OPERATION	ii
BEFORE OPERATION	ii
1. SPECIFICATIONS.....	1
2. INSTALLATION.....	1
3. ADJUSTING THE HEIGHT OF THE KNEE LIFTER	2
4. INSTALLING THE THREAD STAND.....	2
5. LUBRICATION	3
6. ADJUSTING THE AMOUNT OF OIL (OIL SPLASHES) IN THE HOOK.....	4
7. ATTACHING THE NEEDLE	5
8. SETTING THE BOBBIN INTO THE BOBBIN CASE.....	6
9. PRESSER FOOT PRESSURE.....	6
10. HAND LIFTER.....	6
11. ADJUSTING THE HEIGHT OF THE PRESSER BAR	7
12. THREADING THE MACHINE HEAD	7
13. THREAD TENSION.....	8
14. THREAD TAKE-UP SPRING	8
15. ADJUSTING THE THREAD TAKE-UP STROKE	9
16. NEEDLE-TO-HOOK RELATIONSHIP	9
17. HEIGHT OF THE FEED DOG	10
18. TILT OF THE FEED DOG	10
19. ADJUSTING THE FEED TIMING	11
20. PEDAL PRESSURE AND PEDAL STROKE.....	12
21. ADJUSTMENT OF THE PEDAL.....	13
22. PEDAL OPERATION	13

IMPORTANT SAFETY INSTRUCTIONS

To get the most out of the many functions of this machine and operate it in safety, it is necessary to use this machine correctly. Please read this instruction Manual carefully before use. We hope you will enjoy the use of your machine for a long time. Please remember to keep this manual in a safe place.

1. Observe the basic safety measures, including, but not limited to the following ones, whenever you use the machine.
2. Read all the instructions, including, but not limited to this Instruction Manual before you use the machine. In addition, keep this Instruction Manual so that you may read it at anytime when necessary.
3. Use the machine after it has been ascertained that it conforms with safety rules/standards valid in your Country.
4. All safety devices must be in position when the machine is ready for work or in operation. The operation without the specified safety devices is not allowed.
5. This machine shall be operated by appropriately-trained operators.
6. For your personal protection, we recommend that you wear safety glasses.
7. For the following, turn off the power switch or disconnect the power plug of the machine from the receptacle.
 - 7-1 For threading needle(s), looper, spreader etc. And replacing bobbin.
 - 7-2 For replacing part(s) of needle, presser foot, throat plate, looper, spreader, feed dog, needle guard, folder, cloth guide etc.
 - 7-3 For repair work.
 - 7-4 When leaving the working place or when the working place is unattended.
8. If you should allow oil, grease, etc. used with the machine and devices to come in contact with your eyes or skin or swallow any of such liquid by mistake, immediately wash the contacted areas and consult a medical doctor.

9. Tampering with the live parts and devices, regardless of whether the machine is powered, is prohibited.
10. Repair, remodeling and adjustment works must only be done by appropriately trained technicians or specially skilled personnel. Only spare parts designated by can be used for repairs.
11. General maintenance and inspection works have to be done by appropriately trained personnel.
12. Repair and maintenance works of electrical components shall be conducted by qualified electric technicians or under the audit and guidance of specially skilled personnel.
Whenever you find a failure of any of electrical components, immediately stop the machine.
13. Before making repair and maintenance works on the machine equipped with pneumatic parts such as an air cylinder, the air compressor has to be detached from the machine and the compressed air supply has to be cut off. Existing residual air pressure after disconnecting the air compressor from the machine has to be expelled. Exceptions to this are only adjustments and performance checks done by appropriately trained technicians or specially skilled personnel.
14. Periodically clean the machine throughout the period of use.

15. Grounding the machine is always necessary for the normal operation of the machine. The machine has to be operated in an environment that is free from strong noise sources such as high-frequency welder.
16. An appropriate power plug has to be attached to the machine by electric technicians. Power plug has to be connected to a grounded receptacle.

17. The machine is only allowed to be used for the purpose intended. Other uses are not allowed.
18. Remodel or modify the machine in accordance with the safety rules/standards while taking all the effective safety measures. assumes no responsibility for damage by remodeling or modification of the machine.

19. Warning hints are marked with the two shown symbols.





Danger of injury to operator or service staff



Items requiring special attention

FOR SAFE OPERATION

 DANGER	<ol style="list-style-type: none">1. To avoid electrical shock hazards, neither open the cover of the electrical box for the motor nor touch the components mounted inside the electrical box.
 CAUTION	<ol style="list-style-type: none">1. To avoid personal injury, never operate the machine with any of the belt cover, Finger guard or safety devices removed.2. To prevent possible personal injuries caused by being caught in the machine, Keep your fingers, head and clothes away from the handwheel, V belt and the motor while the machine is operation. In addition, place nothing around them.3. To avoid personal injury, never put your hand under the needle when you turn "ON" the power switch or operate the machine.4. To avoid personal injury, never put your fingers into the thread take-up cover while the machine is in operation.5. The hook rotates at a high speed while the machine is in operation. To prevent possible injury to hands, be sure to beep your hands away from the vicinity of the hook during operation. In addition, be sure to turn OFF the power to the machine when replacing the bobbin.6. To avoid possible personal injuries, be careful not to allow your fingers in the machine when tilting/raising the machine head.7. To avoid possible accidents because of abrupt start of the machine, turn OFF the power to the machine when tilting the machine head.8. If your machine is equipped with a servo-motor, the motor does not produce noise while the machine is at rest. To avoid possible accidents due to abrupt start of the machine, be sure to turn OFF the power to the machine.9. To avoid electrical shock hazards, never operate the aewing machine with the ground wire for the power supply removed.10. To prevent possible accidents because of electric shock or damaged electrical components(s), turn OFF the power switch in prior to the connection/disconnection of the power plug.

BEFORE OPERATION



CAUTION:

To avoid malfunction and damage of the machine, confirm the following.

- Before you put the machine into operation for the first time after the set up, clean it thoroughly.
- Remove all dust gathering during transportation and oil it well.
- Confirm that the power plug has been properly connected to the power supply.
- Never use the machine in the state where the voltage type is different from the designated one.
- The direction of rotation of the sewing machine is counterclockwise as observed from the handwheel side. Be careful not to rotate it in reverse direction.

1. SPECIFICATIONS

Application	General fabrics, light-weight and medium-weight materials
Sewing speed	Max. 5,000 rpm
Max. Stitch length	5 mm
Needle	DB x 1 #11 to #18
Presser foot lift	10mm (standard) 13 mm (Max.)
Lubricating oil	White Oil 10

2. INSTALLATION

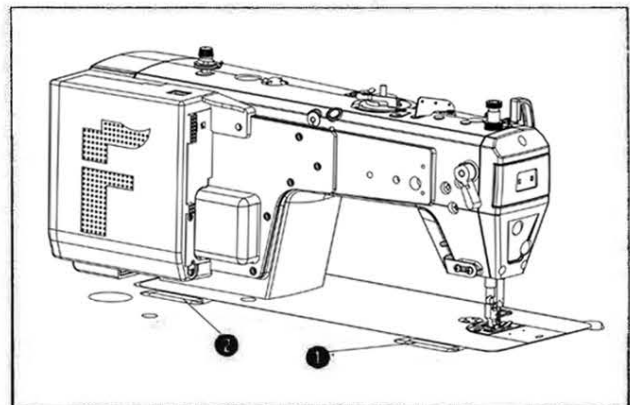
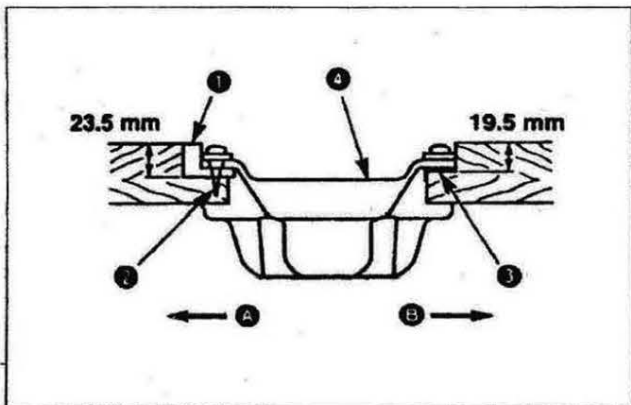
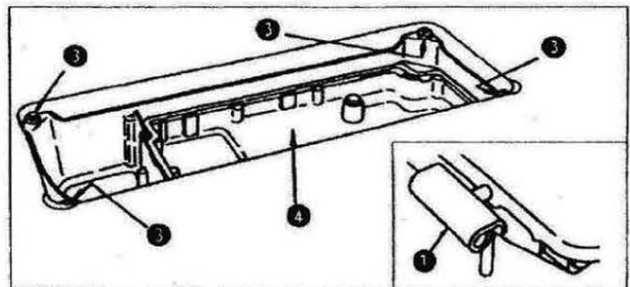
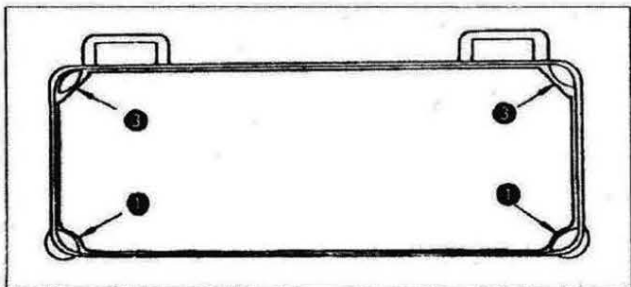

(1) Installing the under cover

- 1) The oil pan should rest on the four corners of the machine table groove.
- 2) Fix two rubber seats ① on side A (operator's side) using nails ② as illustrated above. Fix two cushion seats ③ on side B (hinged side) using a rubber-based adhesive. Then place oil pan ④ on the fixed seats.
- 3) Fit hinge ① into the opening in the machine bed, and fit the machine head to table rubber hinge ② before placing the machine head on cushions ③ on the four corners.

3. ADJUSTING THE HEIGHT OF THE KNEE LIFTER



WARNING:

Turn OFF the power before starting the work so as to prevent accidents caused by abrupt start of the sewing machine.

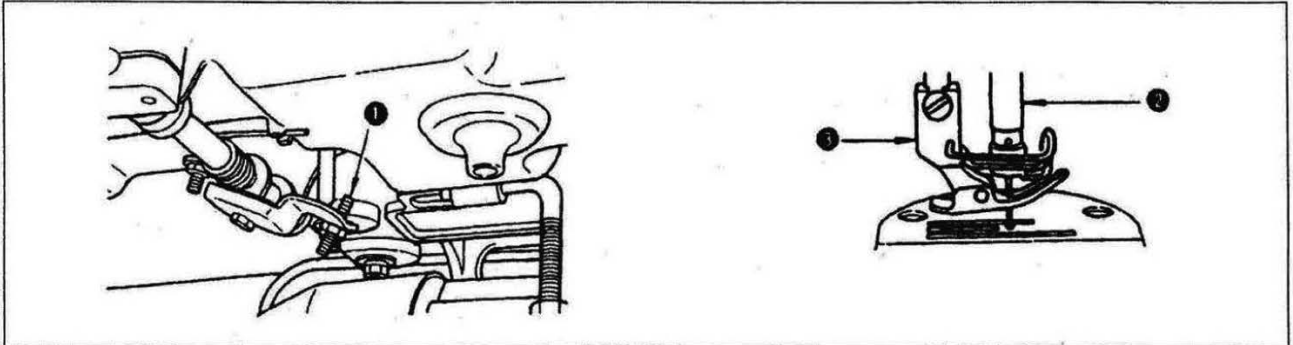

- 1) The standard height of the presser foot lifted using the knee lifter is 10 mm.
- 2) You can adjust the presser foot lift up to 13 mm using knee lifter adjust screw (1).
- 3) When you have adjusted the presser foot lift to over 10 mm, be sure that the bottom end of needle bar (2) in its lowest position does not hit presser foot (3).

4. INSTALLING THE THREAD STAND

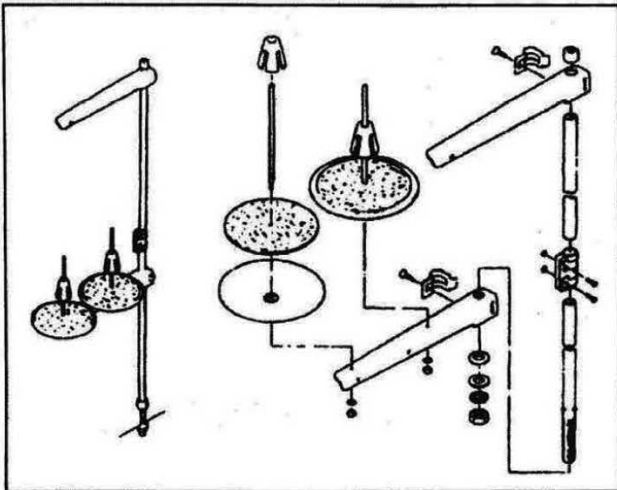

5. LUBRICATION



WARNING:

Turn OFF the power before starting the work so as to prevent accidents caused by abrupt start of the sewing machine.

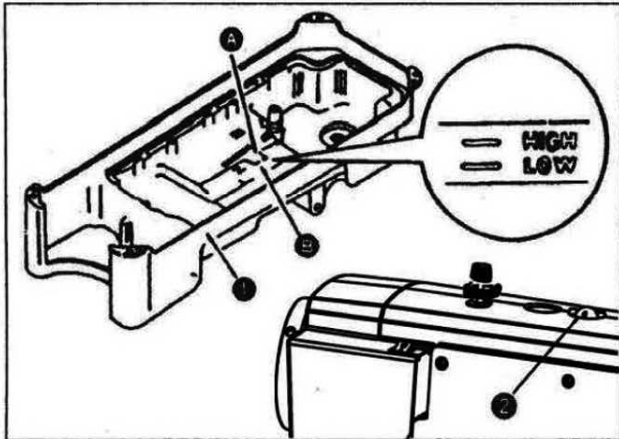

Information on lubrication

- 1) Fill oil pan ① with Machine Oil up to HIGH mark ②.
- 2) When the oil level lowers below LOW mark ③, refill the oil pan with the specified oil.
- 3) When you operate the machine after lubrication, you will see splashing oil through oil sight window ④ if the lubrication is adequate.
- 4) Note that the amount of the splashing oil is unrelated to the amount of the lubricating oil.



When you first operate your machine after setup or after an extended period of disuse, run your machine at 3,000 to 3,500 rpm. for about 10 minutes for the purpose of break-in.

6. ADJUSTING THE AMOUNT OF OIL (OIL SPLASHES) IN THE HOOK



WARNING:

Be extremely careful about the operation of the machine since the amount of oil has to be checked by turning the hook at a high speed.

① Amount of oil (oil splashes) confirmation paper

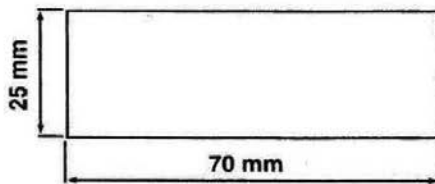

② Position to confirm the amount of oil (oil splashes)

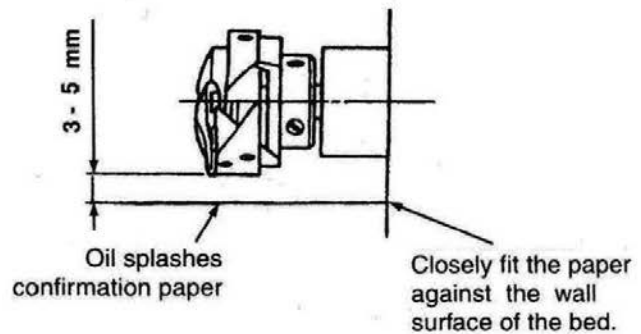

* When carrying out the procedure described below in 2, remove the slide plate and take extreme caution not to allow your fingers to come in contact with the hook.

- 1) If the machine has not been sufficiently warmed up for operation, make the machine run idle for approximately three minutes. (Moderate intermittent operation)
- 2) Place the amount of oil (oil splashes) confirmation paper under the hook while the sewing machine is in operation.
- 3) Confirm the height of the oil surface in the oil reservoir is within the range between "HIGH" and "LOW".
- 4) Confirmation of the amount of oil should be completed in five seconds. (Check the period of time with a watch.)

• **Sample showing the appropriate amount of oil**

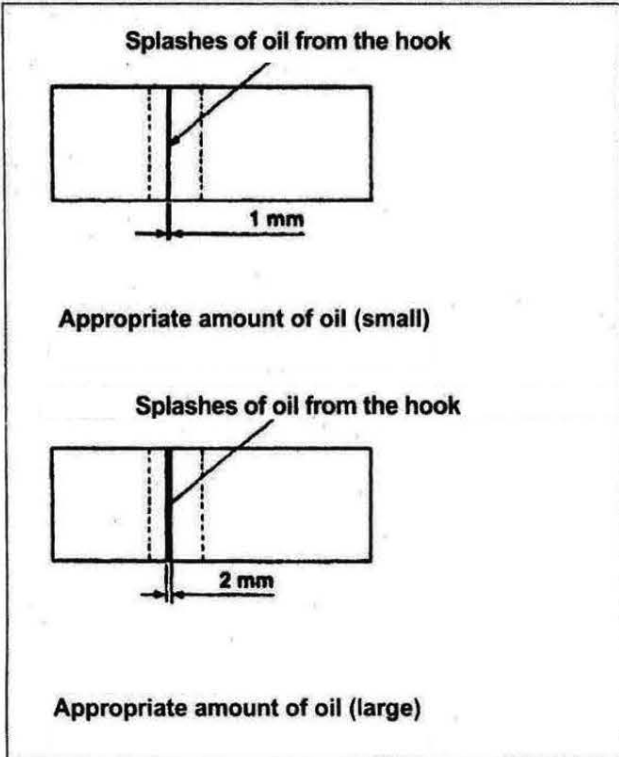

- 1) The amount of oil shown in the samples on the left should be finely adjusted in accordance with sewing processes. Be careful not to excessively increase/decrease the amount of oil in the hook. (If the amount of oil is too small, the hook will be seized (the hook will be hot). If the amount of oil is too much, the sewing product may be stained with oil.)
- 2) Adjust the amount of oil in the hook so that the oil amount (oil splashes) should not change while checking the oil amount three times (on the three sheets of paper)

Adjusting the amount of oil

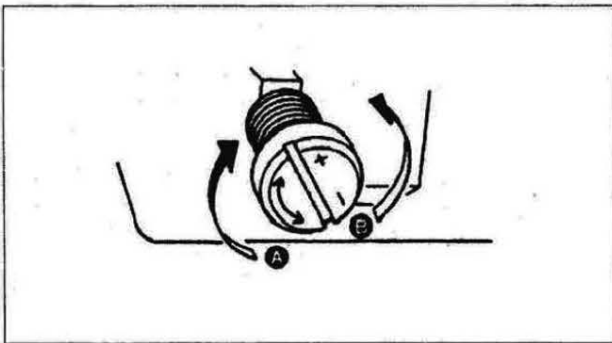

- 1) Turning the oil amount adjustment screw attached on the hook driving shaft front bushing in the "+" direction (in direction **A**) will increase the amount of oil (oil spots) in the hook, or in the "-" direction (in direction **B**) will decrease it.
- 2) After the amount of oil in the hook has been properly adjusted with the oil amount adjustment screw, make the sewing machine run idle for approximately 30 seconds to check the amount of oil in the hook.

7. ATTACHING THE NEEDLE



WARNING:

Turn OFF the power before starting the work so as to prevent accidents caused by abrupt start of the sewing machine.

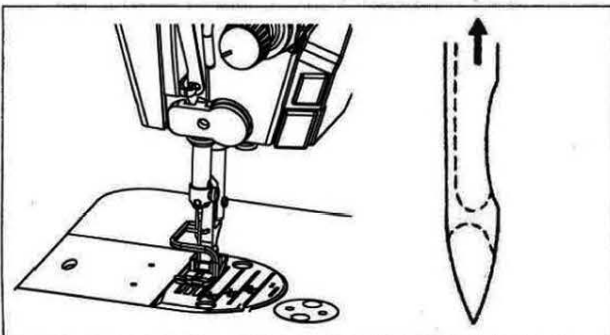

8. SETTING THE BOBBIN INTO THE BOBBIN CASE

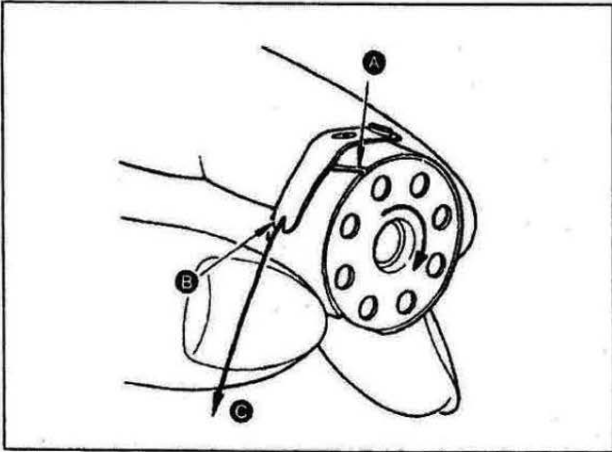

- 1) Pass the thread through thread slit **A**, and pull the thread in direction **B**.
By so doing, the thread will pass under the tension spring and come out from notch **C**.
- 2) Check that the bobbin rotates in the direction of the arrow when thread **C** is pulled.

9. PRESSER FOOT PRESSURE

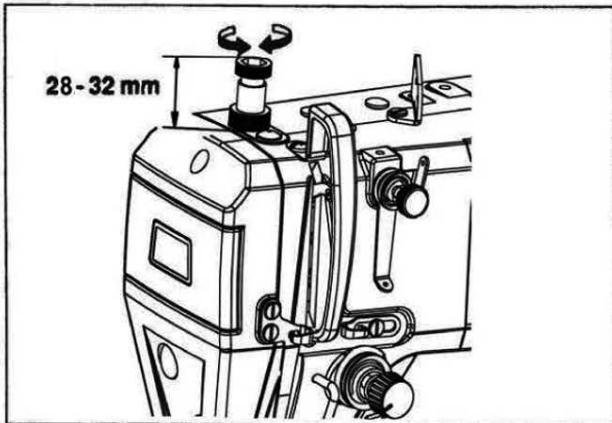

10. HAND LIFTER

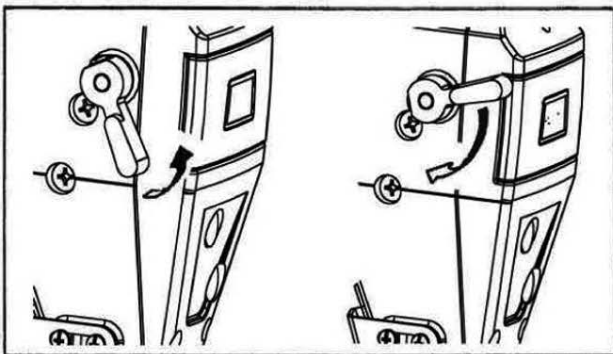

11. ADJUSTING THE HEIGHT OF THE PRESSER BAR



WARNING:

Turn OFF the power before starting the work so as to prevent accidents caused by abrupt start of the sewing machine.

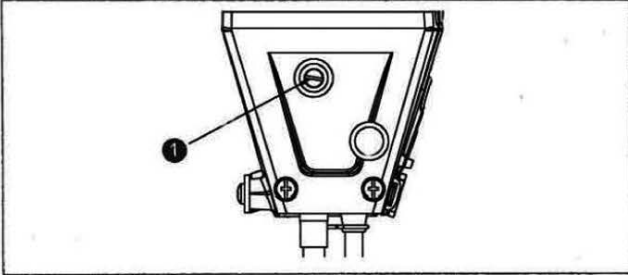

- 1) Loosen setscrew ①, and adjust the presser bar height or the angle of the presser foot.
- 2) After adjustment, securely tighten the setscrew ①.

12. THREADING THE MACHINE HEAD



WARNING:

Turn OFF the power before starting the work so as to prevent accidents caused by abrupt start of the sewing machine.

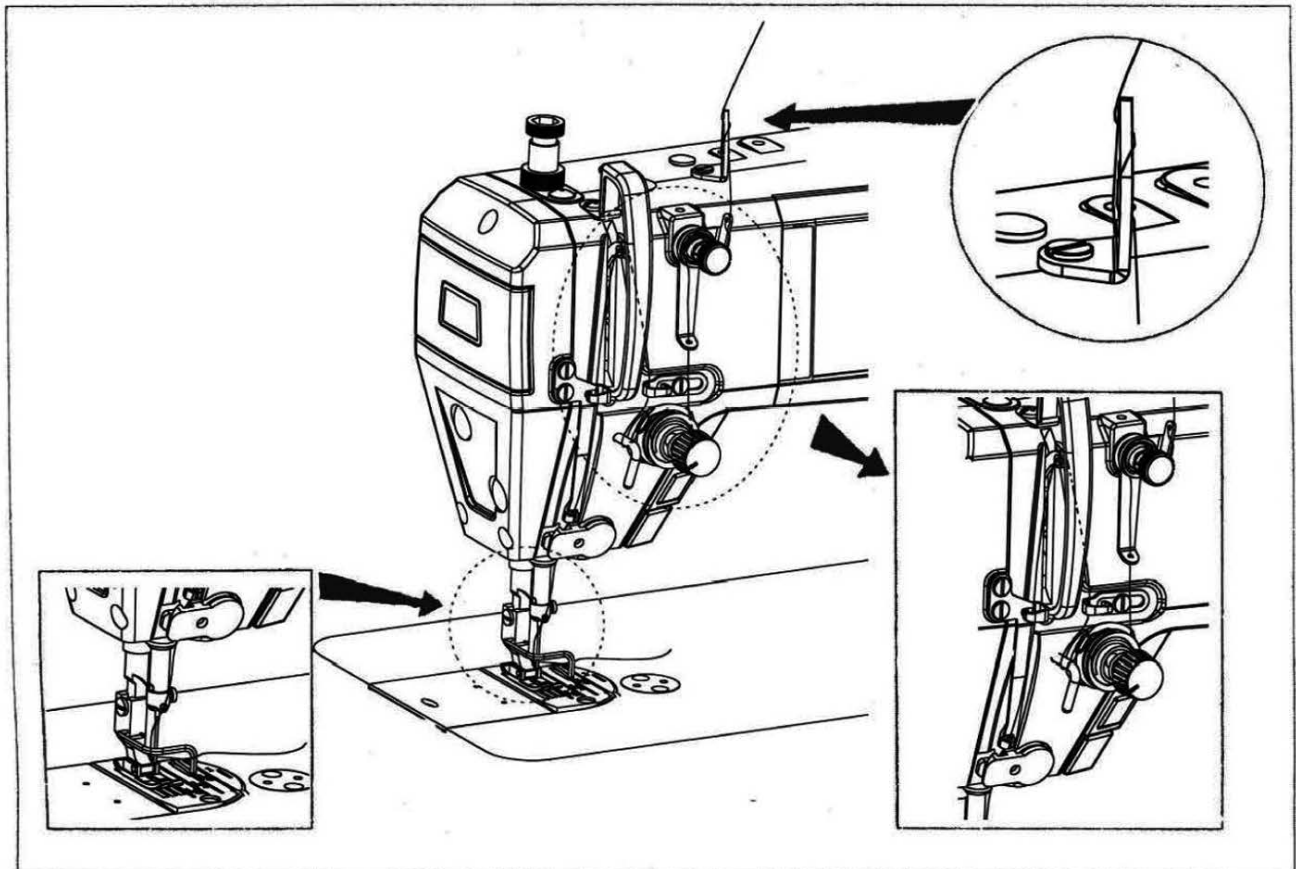

13. THREAD TENSION

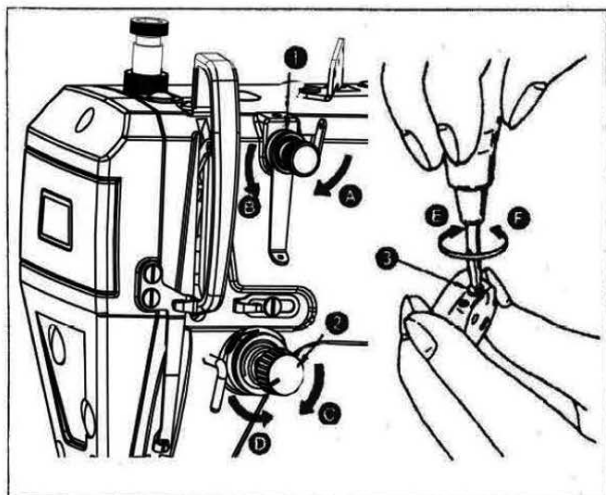

(1) Adjusting the needle thread tension

- 1) As you turn thread tension No.1 nut ① clockwise (in direction ①), the thread remaining on the needle after thread trimming will be shorter.
- 2) As you turn nut ① counterclockwise (in direction ②), the thread length will be longer.
- 3) As you turn thread tension No.2 nut ② clockwise (in direction ③), the needle thread tension will be increased.
- 4) As you turn nut ② counterclockwise (in direction ④), the needle thread tension will be decreased.

(2) Adjusting the bobbin thread tension

- 1) As you turn tension adjust screw ③ clockwise (in direction ⑤), the bobbin thread tension will be increased.
- 2) As you turn screw ③ counterclockwise (in direction ⑥), the bobbin thread tension will be decreased.

14. THREAD TAKE-UP SPRING

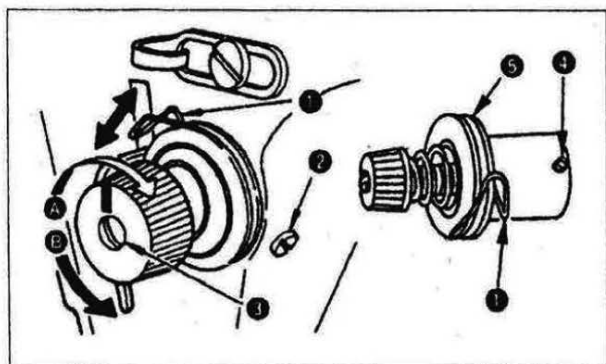

(1) Changing the stroke of thread take-up spring ①

- 1) Loosen setscrew ②.
- 2) As you turn tension post ③ clockwise (in direction ④), the stroke of the thread take-up spring will be increased.
- 3) As you turn the knob counterclockwise (in direction ⑤), the stroke will be decreased.

(2) Changing the pressure of thread take-up spring ①

- 1) Loosen setscrew ②, and remove thread tension (asm) ⑤.
- 2) Loosen setscrew ④.
- 3) As you turn tension post ③ clockwise (in direction ⑥), the pressure will be increased.
- 4) As you turn the post ③ counterclockwise (in direction ⑦), the pressure will be decreased.

15. ADJUSTING THE THREAD TAKE-UP STROKE



WARNING:

Turn OFF the power before starting the work so as to prevent accidents caused by abrupt start of the sewing machine.

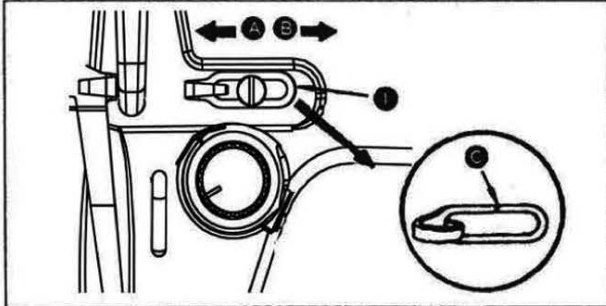

- 1) When sewing heavy-weight materials, move thread guide ① to the left (in direction A) to increase the length of thread pulled out by the thread take-up.
- 2) When sewing light-weight materials, move thread guide ① to the right (in direction B) to decrease the length of thread pulled out by the thread take-up.
- 3) Normally, thread guide ① is positioned in a way that marker line C is aligned with the center of the screw.

16. NEEDLE-TO-HOOK RELATIONSHIP



WARNING:

To avoid possible personal injury due to abrupt start of the machine, turn off the power to the machine and check to be sure that the motor has totally stopped rotating in prior.

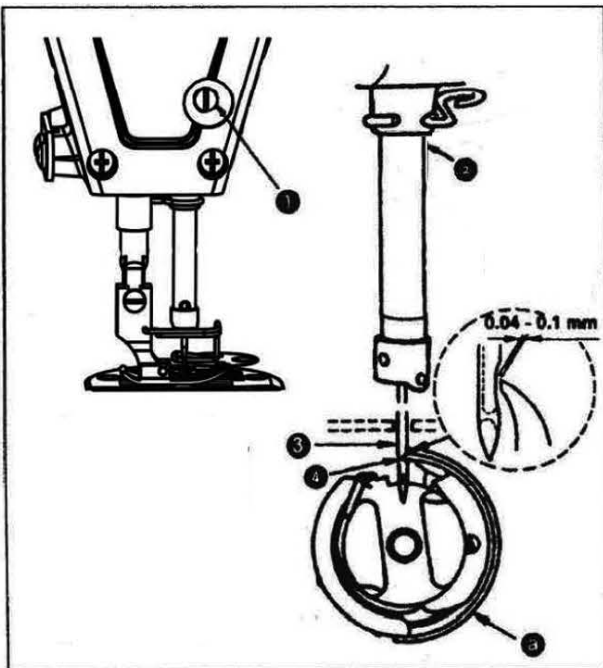

(1) Adjust the timing between the needle and the hook as follows:

1) Turn the handwheel to bring the needle bar down to the lowest point of its stroke, and loosen setscrew ①.

(Adjusting the needle bar height)

2) **(For a DB needle)** Align marker line A on needle bar ② with the bottom end of needle bar lower bushing ③, then tighten setscrew ①.

(For a DA needle) Align marker line C on needle bar ② with the bottom end of needle bar lower bushing ③, then tighten setscrew ①.

(Adjusting position of the hook ③)

3) First, turn the tip of the rotary shuttle upward and rotate the flywheel. When the needle rod rises from the lowest point, observe the matching relationship between the rotary shuttle and the needle.

When the tip of the rotary shuttle is 1-1.5mm above the edge of the needle hole, and the plane of the shuttle tip is 0-0.1mm from the plane of the short groove of the needle (ensure that the shuttle tip is at the center line of the needle), lock the screw of the rotary shuttle.



If the clearance between the blade point of hook and the needle is smaller than the specified value, the blade point of hook will be damaged. If the clearance is larger, stitch skipping will result.

17. HEIGHT OF THE FEED DOG



WARNING:

Turn OFF the power before starting the work so as to prevent accidents caused by abrupt start of the sewing machine.

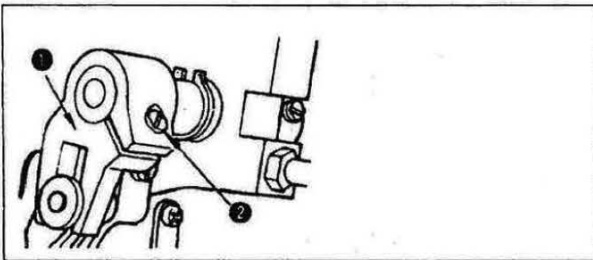

To adjust the height of the feed dog:

- ① Loosen screw ② of crank ①.
- ② Move the feed bar up or down to make adjustment.
- ③ Securely tighten screw ②.



If the clamping pressure is insufficient, the motion of the forked portion becomes heavy.

18. TILT OF THE FEED DOG



WARNING:

Turn OFF the power before starting the work so as to prevent accidents caused by abrupt start of the sewing machine.

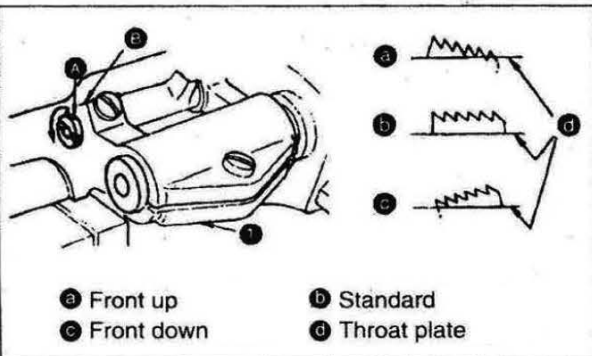

- 1) The standard tilt (horizontal) of the feed dog is obtained when marker dot (A) on the feed bar shaft is aligned with marker dot (B) on feed rocker (1). (the marker dot (B) inclines forward the feed rocker shaft by 90°, as standard).
- 2) To tilt the feed dog with its front up in order to prevent puckering, loosen the setscrew, and turn the feed bar shaft 90° in the direction of the arrow, using a screwdriver.
- 3) To tilt the feed dog with its front down in order to prevent uneven material feed, turn the feed bar shaft 90° in the opposite direction from the arrow. (The standard tilt for.)



Whenever the feed dog tilt is adjusted, the feed dog height will be changed. So, it is necessary to check the height after tilt adjustment.

19. ADJUSTING THE FEED TIMING



WARNING:

To avoid possible personal injury due to abrupt start of the machine, turn off the power to the machine and check to be sure that the motor has totally stopped rotating in prior.

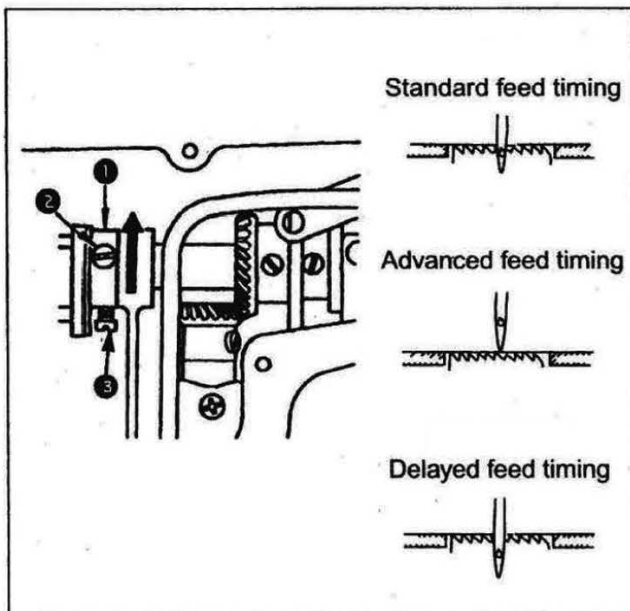

- 1) Loosen screws (2) and (3) in feed eccentric cam (1), move the feed eccentric cam in the direction of the arrow or opposite direction of the arrow, and firmly tighten the screws.
- 2) For the standard adjustment, adjust so that the top surface of feed dog and the top end of needle eyelet are flush with the top surface of throat plate when the feed dog descends below the throat plate.
- 3) To advance the feed timing in order to prevent uneven material feed, move the feed eccentric cam in the direction of the arrow.
- 4) To delay the feed timing in order to increase stitch tightness, move the feed eccentric cam in the opposite, direction from the arrow.



Be careful not to move the feed eccentric cam too far, or else needle breakage may result.

20. PEDAL PRESSURE AND PEDAL STROKE



WARNING:

Turn OFF the power before starting the work so as to prevent accidents caused by abrupt start of the sewing machine.

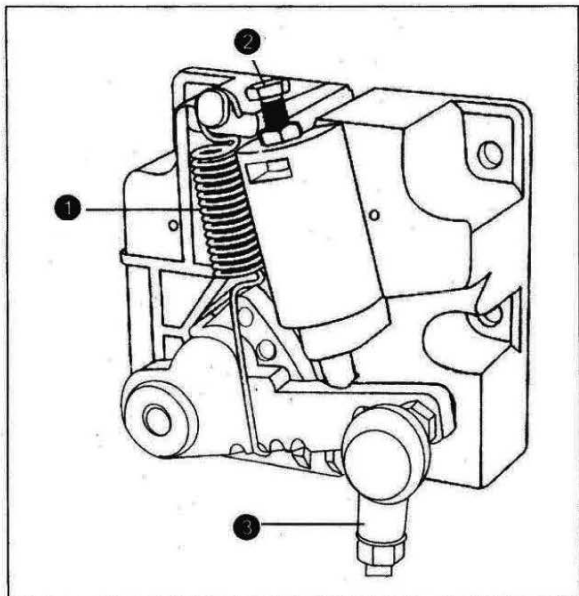

(1) Adjusting the pressure required to depress the front part of the pedal

- 1) This pressure can be changed by changing the mounting position of pedaling pressure adjust spring ❶.
- 2) The pressure decreases when you hook the spring on the left side.
- 3) The pressure increases when you hook the spring on the right side.

(2) Adjusting the pressure required to depress the back part of the pedal

- 1) This pressure can be adjusted using regulator screw ❷.
- 2) The pressure increases as you turn the regulator screw in.
- 3) The pressure decreases as you turn the screw out.

(3) Adjusting the pedal stroke

- 1) The pedal stroke increases when you insert connecting rod ❸ into the right hole.

21. ADJUSTMENT OF THE PEDAL



WARNING:

Turn OFF the power before starting the work so as to prevent accidents caused by abrupt start of the sewing machine.

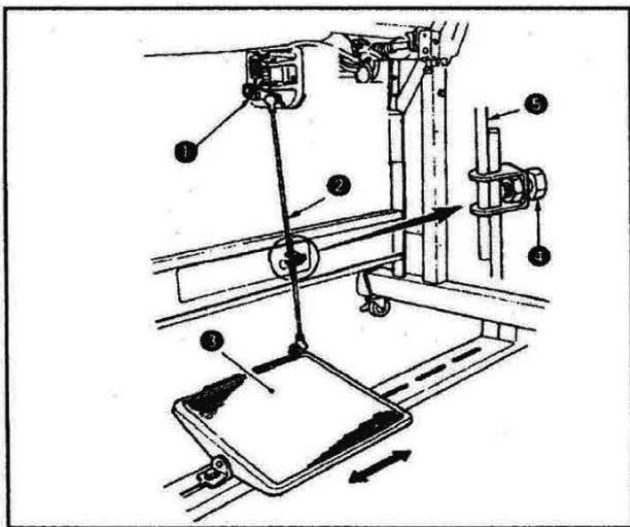

(1) Installing the connecting rod

- 1) Move pedal ③ to the right or left as illustrated by the arrow so that motor control lever ① and connecting rod ② are straightened.

(2) Adjusting the pedal angle

- 1) The pedal tilt can be freely adjusted by changing the length of the connecting rod.
- 2) Loosen adjust screw ④, and adjust the length of connecting rod ⑤.

22. PEDAL OPERATION

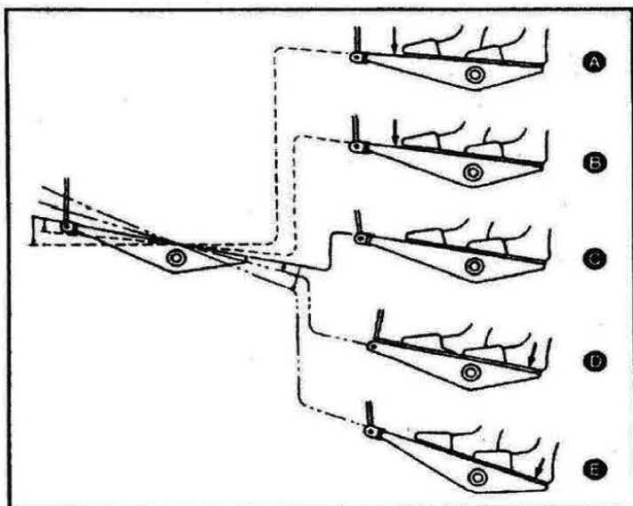

- (1) The pedal operates in four stages.

- 1) Step on the pedal slightly forward to sew at a low speed ②.
- 2) press the pedal forward again to change to high-speed sewing ①. (however, when the switch is set to automatic reverse sewing, high-speed sewing will be performed after the end of reverse sewing).
- 3) reverse the pedal to the position where the foot is gently placed on the pedal, and the sewing machine stops. ③ (needle up stop or down stop position)
- 4) press the pedal backward with force, which is a tangent action ④. When using the automatic presser foot lifting device, a level 1 switch is added between the stop and the tangent for automatic presser foot lifting ⑤.

Company Name: JUKI SINGAPORE PTE LTD.
ADD: 20 BENDEMEER ROAD, #04-12 BS BENDEMEER CENTRE SINGAPORE 339914
Tel: (65)6553-4388
HP: <http://www.juki.com.sg/>
E-mail: we.sgp-sales@ml.juki.com

Company Name: Juki Machinery Vietnam Company Ltd.
ADD: 153 HOA LAN STR., WARD 2, PHU NHUAN DIST., HO CHI MINH CITY, VIETNAM
Tel: (84)28-35178833
FAX: (84)28-35178318
E-mail: sales@jukinv.com

Company Name: Juki Machinery Bangladesh Ltd
ADD: NATORE TOWER (5TH FLOOR) PLOT#32-D & 32-E, ROAD#02, SECTOR#03,
UTTARA MODEL TOWN, DHAKA, BANGLADESH
Tel: (880)2-48954731
FAX: (880)2-48954733
E-mail: vl.jmbl-info@ml.juki.com

Company Name: Juki India Private Limited
ADD: GROUND AND 1ST FLOOR, NO.1090/I, 18TH CROSS ROAD, 3RD SECTOR,
HSR LAYOUT BANGALORE-560 102, KARNATAKA STATE, INDIA
Tel: (91)80-4251-1900
FAX: (91)80-4251-1999
HP: <http://jukiindia.com/>
E-mail: jukibl@jukiindia.com

Company Name: JUKI CENTRAL EUROPE
ADD: UL. POLECKI 21 (PLATAN PARK C) 02-822 WARSAW, POLAND
Tel: (48)22-545-0400
FAX: (48) 22-5450411
HP: <http://jukieurope.com/>

Company Name: JUKI America INC
ADD: 8500 NW 17TH STREET, SUITE 100, DORAL, FL 33126-1035, U. S. A.
Tel: (1)305-594-0059
HP: <https://juki.com/>